

Cast Iron Sheaves - **Heavy Duty**
Bushed, **One and Two Groove**
A-B TB Sheaves
Order part number size
Example: 1B34-1210

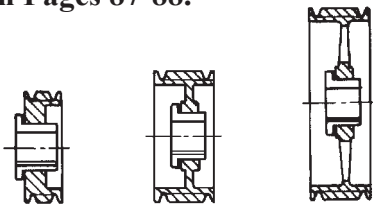

For A, AX, B & BX V-Belts.
See pages 102-108.
Order TB bushings separately
Stock Bushings Located
on Pages 87-88.



Type 1 Solid
Type 2 Web
Type 3 Spoke

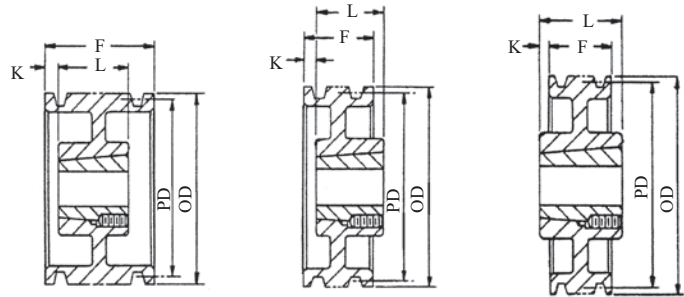

Type A
Type E
Type F

O.D.	P.D.		1 Groove F = 1B34-1210 THRU 1B154-2517 = 1 1B184-2517 = 1 1/8						2 Groove F = 1 3/4					
	A	B	Part No.	Bush	Type	K	L	WT.	Part No.	Bush	Type	K	L	WT.
3.75	3.00	3.40	1B34-1210	1210	A-1	0	1	2.2	2B34-1210	1210	A-1	3/4	1	2.9
3.95	3.20	3.60	1B36-1210	1210	A-1	0	1	2.6	2B36-1210	1210	A-1	3/4	1	3.8
4.15	3.40	3.80	1B38-1610	1610	A-1	0	1	2.8	2B38-1610	1610	A-1	3/4	1	3.0
4.35	3.60	4.00	1B40-1610	1610	A-1	0	1	3.0	2B40-1610	1610	A-1	3/4	1	3.8
4.55	3.80	4.20	1B42-1610	1610	A-1	0	1	3.5	2B42-1610	1610	A-1	3/4	1	3.9
4.75	4.00	4.40	1B44-1610	1610	A-1	0	1	3.8	2B44-1610	1610	A-1	3/4	1	3.9
4.95	4.20	4.60	1B46-1610	1610	A-1	0	1	4.0	2B46-1610	1610	A-1	3/4	1	4.5
5.15	4.40	4.80	1B48-1610	1610	A-1	0	1	4.5	2B48-1610	1610	A-1	3/4	1	5.3
5.35	4.60	5.00	1B50-1610	1610	A-1	0	1	4.8	2B50-1610	1610	A-1	3/4	1	5.6
5.55	4.80	5.20	1B52-1610	1610	A-1	0	1	5.0	2B52-1610	1610	A-1	3/4	1	6.1
5.75	5.00	5.40	1B54-1610	1610	A-1	0	1	5.5	2B54-1610	1610	A-1	3/4	1	6.5
5.95	5.20	5.60	1B56-1610	1610	A-1	0	1	6.0	2B56-1610	1610	A-1	3/4	1	7.4
6.15	5.40	5.80	1B58-1610	1610	A-1	0	1	6.3	2B58-1610	1610	A-1	3/4	1	8.0
6.35	5.60	6.00	1B60-1610	1610	A-1	0	1	6.7	2B60-1610	1610	A-1	3/4	1	8.9
6.55	5.80	6.20	1B62-1610	1610	A-1	0	1	7.0	2B62-1610	1610	A-1	3/4	1	7.6
6.75	6.00	6.40	1B64-1610	1610	A-1	0	1	8.0	2B64-1610	1610	A-1	3/4	1	7.8
6.95	6.20	6.60	1B66-1610	1610	A-1	0	1	8.5	2B66-1610	1610	A-1	3/4	1	8.3
7.15	6.40	6.80	1B68-1610	1610	A-1	0	1	9.0	2B68-1610	1610	A-1	3/4	1	8.8
7.75	7.00	7.40	1B74-2517	2517	E-1	0	1 3/4	9.4	2B74-2517	2517	A-1	0	1 3/4	11.5
8.95	8.20	8.60	1B86-2517	2517	E-2	0	1 3/4	12.0	2B86-2517	2517	A-2	0	1 3/4	16.0
9.75	9.00	9.40	1B94-2517	2517	E-2	0	1 3/4	14.0	2B94-2517	2517	A-2	0	1 3/4	15.5
11.35	10.60	11.00	1B110-2517	2517	E-2	0	1 3/4	18.0	2B110-2517	2517	A-2	0	1 3/4	18.9
12.75	12.00	12.40	1B124-2517	2517	F-3	1/4	1 3/4	18.5	2B124-2517	2517	A-3	0	1 3/4	21.1
15.75	15.00	15.40	1B154-2517	2517	F-3	1/4	1 3/4	19.0	2B154-2517	2517	A-3	0	1 3/4	24.8
18.75	18.00	18.40	1B184-2517	2517	F-3	3/16	1 3/4	24.0	2B184-2517	2517	A-3	0	1 3/4	32.3
20.35	19.60	20.00							2B200-3020	3020	F-3	0	2	42.3
25.35	24.60	25.00							2B250-3020	3020	F-3	0	2	50.3
30.35	29.60	30.00							2B300-3020	3020	F-3	0	2	68.8

Note: Cast iron sheaves may not exceed 6500 FPM. This speed **DOES NOT** specify if dynamic balancing (2 plane) is required. Contact customer service to verify whether dynamic balancing is required.

TB Bushing Sheaves

Cast Iron Sheaves - Heavy Duty
Bushed, Three and Four Groove
A-B TB Sheaves
Order part number size
Example: 3B34-1210



For A, AX, B & BX V-Belts.
See pages 102-108.
Order TB bushings separately
Stock Bushings Located
on Pages 87-88.

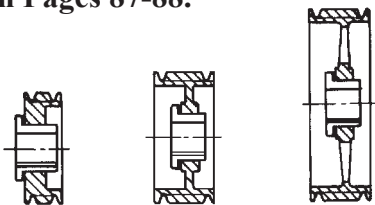

Type 1 Solid Type 2 Web Type 3 Spoke

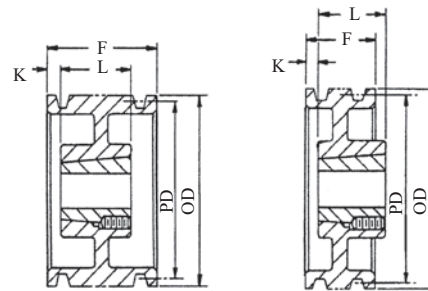

Type A Type E

O.D.	P.D.		3 Groove F = 2 1/2						4 Groove F = 3 1/4					
	A	B	Part No.	Bush	Type	K	L	WT.	Part No.	Bush	Type	K	L	WT.
3.75	3.00	3.40	3B34-1210	1210	A-1	1 1/2	1	3.0	4B34-1210	1210	A-1	2 1/4	1	3.0
3.95	3.20	3.60	3B36-1210	1210	A-1	1 1/2	1	3.5	4B36-1210	1210	A-1	2 1/4	1	3.5
4.15	3.40	3.80	3B38-1610	1610	A-1	1 1/2	1	4.0	4B38-1610	1610	A-1	2 1/4	1	4.0
4.35	3.60	4.00	3B40-1610	1610	A-1	1 1/2	1	5.0	4B40-1610	1610	A-1	2 1/4	1	5.0
4.55	3.80	4.20	3B42-1610	1610	A-1	1 1/2	1	6.0	4B42-1610	1610	A-1	2 1/4	1	5.5
4.75	4.00	4.40	3B44-1610	1610	A-1	1 1/2	1	6.5	4B44-1610	1610	A-1	2 1/4	1	6.0
4.95	4.20	4.60	3B46-1610	1610	A-1	1 1/2	1	7.0	4B46-1610	1610	A-1	2 1/4	1	7.0
5.15	4.40	4.80	3B48-1610	1610	A-1	1 1/2	1	8.0	4B48-1610	1610	A-1	2 1/4	1	8.0
5.35	4.60	5.00	3B50-1610	1610	A-1	1 1/2	1	8.5	4B50-2517	2517	A-1	1 1/2	1 3/4	8.5
5.55	4.80	5.20	3B52-1610	1610	A-1	1 1/2	1	9.0	4B52-2517	2517	A-1	1 1/2	1 3/4	9.0
5.75	5.00	5.40	3B54-2517	2517	A-1	1 1/2	1 3/4	9.5	4B54-2517	2517	A-1	1 1/2	1 3/4	9.5
5.95	5.20	5.60	3B56-2517	2517	A-1	1 1/2	1 3/4	10.0	4B56-2517	2517	A-1	1 1/2	1 3/4	10.0
6.15	5.40	5.80	3B58-2517	2517	A-1	3/4	1 3/4	10.5	4B58-2517	2517	A-1	1 1/2	1 3/4	12.0
6.35	5.60	6.00	3B60-2517	2517	A-1	3/4	1 3/4	11.0	4B60-2517	2517	A-1	1 1/2	1 3/4	12.5
6.55	5.80	6.20	3B62-2517	2517	A-1	3/4	1 3/4	11.5	4B62-2517	2517	A-1	1 1/2	1 3/4	13.0
6.75	6.00	6.40	3B64-2517	2517	A-1	3/4	1 3/4	12.0	4B64-2517	2517	A-1	1 1/2	1 3/4	14.0
6.95	6.20	6.60	3B66-2517	2517	A-1	3/4	1 3/4	12.3	4B66-2517	2517	A-1	1 1/2	1 3/4	15.0
7.15	6.40	6.80	3B68-2517	2517	A-1	3/4	1 3/4	12.8	4B68-2517	2517	A-1	1 1/2	1 3/4	16.0
7.75	7.00	7.40	3B74-2517	2517	A-1	3/4	1 3/4	16.0	4B74-2517	2517	A-1	1 1/2	1 3/4	20.0
8.95	8.20	8.60	3B86-2517	2517	A-2	3/4	1 3/4	19.0	4B86-2517	2517	A-2	1 1/2	1 3/4	21.0
9.75	9.00	9.40	3B94-2517	2517	A-2	3/4	1 3/4	21.0	4B94-2517	2517	A-2	1 1/2	1 3/4	23.0
11.35	10.60	11.00	3B110-2517	2517	A-2	3/4	1 3/4	24.0	4B110-2517	2517	A-2	1 1/2	1 3/4	28.0
12.75	12.00	12.40	3B124-2517	2517	A-3	0	1 3/4	28.0	4B124-2517	2517	A-3	3/8	1 3/4	34.0
15.75	15.00	15.40	3B154-2517	2517	A-3	0	1 3/4	30.0	4B154-2517	2517	A-3	3/8	1 3/4	42.0
18.75	18.00	18.40	3B184-2517	2517	A-3	0	1 3/4	44.0	4B184-2517	2517	A-3	1/2	1 3/4	53.0
20.35	19.60	20.00	3B200-3020	3020	A-3	0	2	58.0	4B200-3030	3030	A-3	1/2	3	63.0
25.35	24.60	25.00	3B250-3020	3020	A-3	0	2	74.0	4B250-3030	3030	A-3	0	3	80.0
30.35	29.60	30.00	3B300-3020	3020	A-3	0	2	84.0	4B300-3030	3030	A-3	0	3	100.0
38.35	37.60	38.00	3B380-3020	3020	E-3	0	2	135.0	4B380-3030	3030	A-3	0	3	142.0

Note: Cast iron sheaves may not exceed 6500 FPM. This speed **DOES NOT** specify if dynamic balancing (2 plane) is required. Contact customer service to verify whether dynamic balancing is required.

Cast Iron Sheaves - Heavy Duty
Bushed, **One and Two Groove**
3V TB Sheaves
Order part number size
Example: 1/3V265-1108

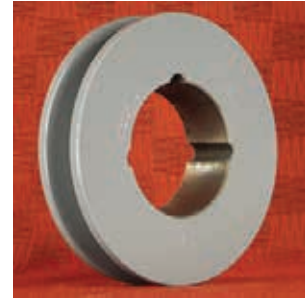

For 3V & 3VX V-Belts.
See pages 113-114
Order TB bushings separately
Stock Bushings Located
on Pages 87-88.

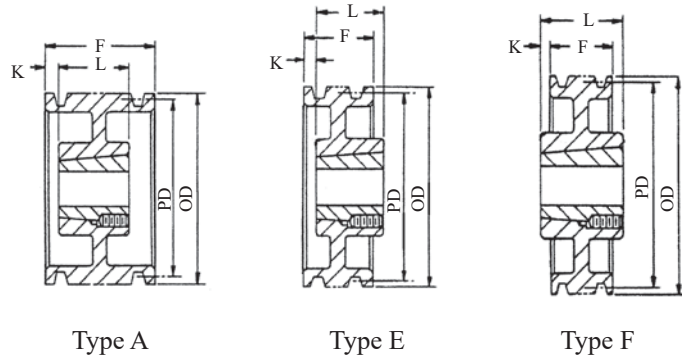
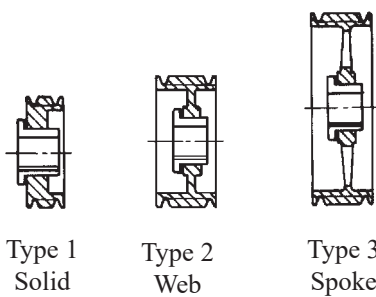

Diameters		1 Groove F = 11/16 1/3V 800-2517 & 1/3V1060-2517 F=3/4 1/3V1400-2517 & 1/3V1900-3020 F=13/16						2 Groove F = 1 3/32					
O.D.	P.D.	Part No.	Bush	Type	K	L	WT.	Part No.	Bush	Type	K	L	WT.
2.65	2.60	1/3V265-1108	1108	F-1	3/16	7/8	.8	2/3V265-1108	1108	A-1	7/32	7/8	.8
2.80	2.75	1/3V280-1108	1108	F-1	3/16	7/8	.9	2/3V280-1108	1108	A-1	7/32	7/8	.9
3.00	2.95	1/3V300-1108	1108	F-1	3/16	7/8	1.0	2/3V300-1210	1210	A-1	3/32	1	1.4
3.15	3.10	1/3V315-1108	1108	F-1	3/16	7/8	1.3	2/3V315-1210	1210	A-1	3/32	1	1.6
3.35	3.30	1/3V335-1610	1610	E-1	0	1	1.5	2/3V335-1610	1610	A-1	3/32	1	1.7
3.65	3.60	1/3V365-1610	1610	E-1	0	1	2.0	2/3V365-1610	1610	A-1	3/32	1	2.0
4.12	4.07	1/3V412-1610	1610	E-1	0	1	2.3	2/3V412-1610	1610	A-1	3/32	1	2.1
4.50	4.45	1/3V450-1610	1610	E-1	0	1	3.0	2/3V450-1610	1610	A-1	3/32	1	2.7
4.75	4.70	1/3V475-1610	1610	E-1	0	1	3.3	2/3V475-1610	1610	A-1	3/32	1	3.0
5.00	4.95	1/3V500-1610	1610	E-1	0	1	3.5	2/3V500-1610	1610	A-1	3/32	1	4.0
5.30	5.25	1/3V530-1610	1610	E-2	0	1	3.8	2/3V530-1610	1610	A-2	3/32	1	5.0
5.60	5.55	1/3V560-1610	1610	E-2	0	1	4.0	2/3V560-1610	1610	A-2	3/32	1	6.0
6.00	5.95	1/3V600-1610	1610	E-2	0	1	5.0	2/3V600-1610	1610	A-2	3/32	1	7.0
6.50	6.45	1/3V650-1610	1610	E-2	0	1	6.0	2/3V650-1610	1610	A-2	3/32	1	8.0
6.90	6.85	1/3V690-1610	1610	E-2	0	1	7.0	2/3V690-1610	1610	A-2	3/32	1	9.0
8.00	7.95	1/3V800-2517	2517	E-2	0	1 3/4	9.0	2/3V800-2517	2517	E-2	0	1 3/4	10.0
10.60	10.55	1/3V1060-2517	2517	E-3	0	1 3/4	13.0	2/3V1060-2517	2517	E-3	0	1 3/4	14.0
14.00	13.95	1/3V1400-2517	2517	E-3	0	1 3/4	15.0	2/3V1400-2517	2517	E-3	0	1 3/4	18.0
19.00	18.95	1/3V1900-3020	3020	E-3	0	2	27.0	2/3V1900-3020	3020	E-3	0	2	32.0
25.00	24.95							2/3V2500-3020	3020	F-3	1/8	2	45.0

Note: Cast iron sheaves may not exceed 6500 FPM.
This speed **DOES NOT** specify if dynamic balancing
(2 plane) is required. Contact customer service to
verify whether dynamic balancing is required.

TB Bushing Sheaves

Cast Iron Sheaves - Heavy Duty
Bushed, Three and Four Groove
3V TB Sheaves
Order part number size
Example: 3/3V265-1108

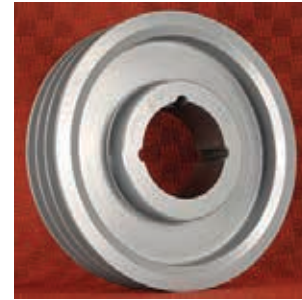

For 3V & 3VX V-Belts.
See pages 113-114
Order TB bushings separately
Stock Bushings Located
on Pages 87-88.

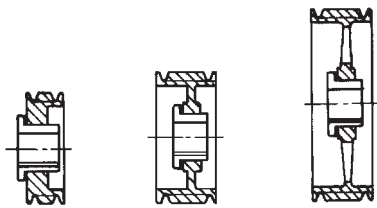

Type 1 Solid
Type 2 Web
Type 3 Spoke

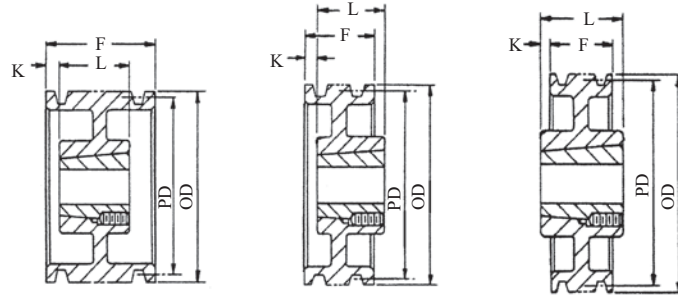

Type A
Type E
Type F

Diameters		3 Groove F = 1 1/2						4 Groove F = 1 29/32					
O.D.	P.D.	Part No.	Bush	Type	K	L	WT.	Part No.	Bush	Type	K	L	WT.
2.65	2.60	3/3V265-1108	1108	A-1	5/8	7/8	1.0	4/3V265-1108	1108	A-1	1 1/32	7/8	1.2
2.80	2.75	3/3V280-1108	1108	A-1	5/8	7/8	1.1	4/3V280-1108	1108	A-1	1 1/32	7/8	1.3
3.00	2.95	3/3V300-1210	1210	A-1	1/2	1	1.8	4/3V300-1210	1210	A-1	29/32	1	2.1
3.15	3.10	3/3V315-1210	1210	A-1	1/2	1	2.0	4/3V315-1210	1210	A-1	29/32	1	2.2
3.35	3.30	3/3V335-1610	1610	A-1	1/2	1	2.3	4/3V335-1610	1610	A-1	29/32	1	2.4
3.65	3.60	3/3V365-1610	1610	A-1	1/2	1	2.6	4/3V365-1610	1610	A-1	29/32	1	2.8
4.12	4.07	3/3V412-1610	1610	A-1	1/2	1	3.0	4/3V412-1610	1610	A-1	29/32	1	3.0
4.50	4.45	3/3V450-1610	1610	A-1	1/2	1	3.2	4/3V450-1610	1610	A-1	29/32	1	4.0
4.75	4.70	3/3V475-1610	1610	A-1	1/2	1	4.0	4/3V475-1610	1610	A-1	29/32	1	5.0
5.00	4.95	3/3V500-1610	1610	A-1	1/2	1	4.5	4/3V500-1610	1610	A-1	29/32	1	5.5
5.30	5.25	3/3V530-1610	1610	A-1	1/2	1	5.0	4/3V530-1610	1610	A-1	29/32	1	6.0
5.60	5.55	3/3V560-1610	1610	A-1	1/2	1	6.0	4/3V560-1610	1610	A-1	29/32	1	7.0
6.00	5.95	3/3V600-2517	2517	E-1	0	1 3/4	7.0	4/3V600-2517	2517	A-1	5/32	1 3/4	8.0
6.50	6.45	3/3V650-2517	2517	E-1	0	1 3/4	9.0	4/3V650-2517	2517	A-1	5/32	1 3/4	10.0
6.90	6.85	3/3V690-2517	2517	E-1	0	1 3/4	10.0	4/3V690-2517	2517	A-1	5/32	1 3/4	12.0
8.00	7.95	3/3V800-2517	2517	E-2	0	1 3/4	15.0	4/3V800-2517	2517	A-2	5/32	1 3/4	18.0
10.60	10.55	3/3V1060-2517	2517	E-3	0	1 3/4	18.0	4/3V1060-2517	2517	A-3	5/32	1 3/4	19.0
14.00	13.95	3/3V1400-2517	2517	E-3	0	1 3/4	20.0	4/3V1400-2517	2517	A-3	0	1 3/4	22.0
19.00	18.95	3/3V1900-3020	3020	E-3	0	2	36.0	4/3V1900-3020	3020	E-3	0	2	45.0
25.00	24.95	3/3V2500-3020	3020	E-3	0	2	47.0	4/3V2500-3020	3020	E-3	0	2	63.0
33.50	33.45	3/3V3350-3020	3020	F-3	1/4	2	76.0	4/3V3350-3030	3030	F-3	35/64	3	80.0

Note: Cast iron sheaves may not exceed 6500 FPM.
This speed **DOES NOT** specify if dynamic balancing
(2 plane) is required. Contact customer service to
verify whether dynamic balancing is required.

Cast Iron Sheaves - **Heavy Duty**
Bushed, **Five and Six Groove**
3V TB Sheaves
Order part number size
Example: 5/3V475-2517

For 3V & 3VX V-Belts.
See pages 113-114
Order TB bushings separately
Stock Bushings Located
on Pages 87-88.

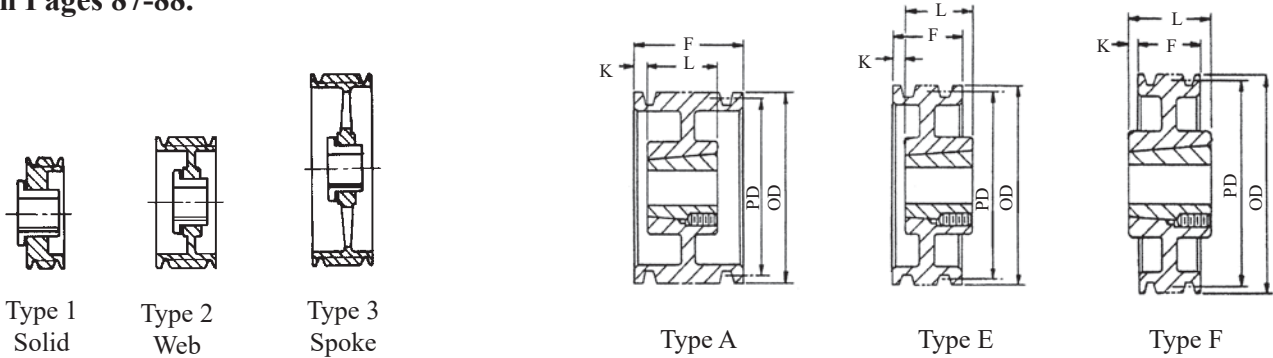

Diameters		5 Groove F = 2 5/16						6 Groove F = 2 23/32					
O.D.	P.D.	Part No.	Bush	Type	K	L	WT.	Part No.	Bush	Type	K	L	WT.
4.75	4.70	5/3V475-2517	2517	A-1	9/16	1 3/4	4.0	6/3V475-2517	2517	A-1	31/32	1 3/4	4.4
5.00	4.95	5/3V500-2517	2517	A-1	9/16	1 3/4	4.8	6/3V500-2517	2517	A-1	31/32	1 3/4	5.4
5.30	5.25	5/3V530-2517	2517	A-1	9/16	1 3/4	5.9	6/3V530-2517	2517	A-1	31/32	1 3/4	6.5
5.60	5.55	5/3V560-2517	2517	A-1	9/16	1 3/4	7.0	6/3V560-2517	2517	A-1	31/32	1 3/4	7.7
6.00	5.95	5/3V600-2517	2517	A-1	9/16	1 3/4	8.0	6/3V600-2517	2517	A-1	31/32	1 3/4	9.5
6.50	6.45	5/3V650-2517	2517	A-1	9/16	1 3/4	11.0	6/3V650-2517	2517	A-1	31/32	1 3/4	12.0
6.90	6.85	5/3V690-2517	2517	A-1	9/16	1 3/4	13.0	6/3V690-2517	2517	A-1	31/32	1 3/4	13.0
8.00	7.95	5/3V800-2517	2517	A-2	9/16	1 3/4	19.0	6/3V800-2517	2517	A-2	31/32	1 3/4	20.0
10.60	10.55	5/3V1060-2517	2517	A-3	9/16	1 3/4	21.0	6/3V1060-2517	2517	A-3	31/32	1 3/4	21.0
14.00	13.95	5/3V1400-2517	2517	A-3	0	1 3/4	30.0	6/3V1400-2517	2517	A-3	0	1 3/4	30.0
19.00	18.95	5/3V1900-3020	3020	E-3	0	2	51.0	6/3V1900-3020	3020	E-3	0	2	51.0
25.00	24.95	5/3V2500-3030	3030	E-3	0	2	76.0	6/3V2500-3030	3030	E-3	0	2	81.0
33.50	33.45	5/3V3350-3030	3030	F-3	11/32	3	97.0	6/3V3350-3030	3030	F-3	9/64	3	110.0

Note: Cast iron sheaves may not exceed 6500 FPM.
This speed **DOES NOT** specify if dynamic balancing
(2 plane) is required. Contact customer service to
verify whether dynamic balancing is required.

TB Bushing Sheaves

Cast Iron Sheaves - Heavy Duty
Bushed, Two and Three Groove
5V TB Sheaves

Order part number size
Example: 2/5V440-1610

For 5V & 5VX V-Belts.
See pages 113, 115 & 116.
Order TB bushings separately
Stock Bushings Located
on Pages 87-88.

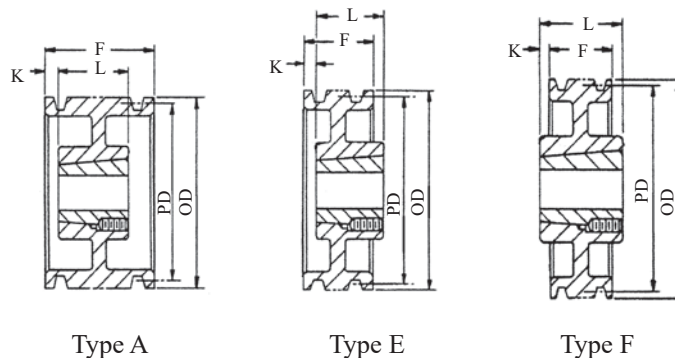
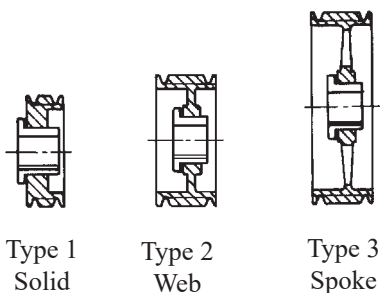
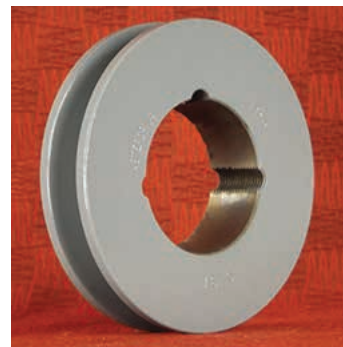

Diameters		2 Groove F = 1 11/16						3 Groove F = 2 3/8					
O.D.	P.D.	Part No.	Bush	Type	K	L	WT.	Part No.	Bush	Type	K	L	WT.
4.40	4.30	2/5V440-1610	1610	A-1	11/16	1	3.0	3/5V440-1610	1610	A-1	1 3/8	1	4.0
4.65	4.55	2/5V465-1610	1610	A-1	11/16	1	3.0	3/5V465-1610	1610	A-1	1 3/8	1	5.0
4.90	4.80	2/5V490-1610	1610	A-1	11/16	1	4.0	3/5V490-1610	1610	A-1	1 3/8	1	5.0
5.20	5.10	2/5V520-1610	1610	A-1	11/16	1	4.0	3/5V520-1610	1610	A-1	1 3/8	1	6.0
5.50	5.40	2/5V550-1610	1610	A-1	11/16	1	5.0	3/5V550-1610	1610	A-1	1 1/8	1	6.0
5.90	5.80	2/5V590-1610	1610	A-1	11/16	1	6.0	3/5V590-2517	2517	A-1	5/8	1 3/4	7.0
6.30	6.20	2/5V630-1610	1610	A-1	11/16	1	7.0	3/5V630-2517	2517	A-1	5/8	1 3/4	9.0
6.70	6.60	2/5V670-1610	1610	A-1	11/16	1	9.0	3/5V670-2517	2517	A-1	5/8	1 3/4	10.0
7.10	7.00	2/5V710-2517	2517	E-1	0	1 3/4	10.0	3/5V710-2517	2517	A-1	5/8	1 3/4	13.0
7.50	7.40	2/5V750-2517	2517	E-1	0	1 3/4	12.0	3/5V750-2517	2517	A-1	5/8	1 3/4	15.0
8.00	7.90	2/5V800-2517	2517	E-2	0	1 3/4	14.0	3/5V800-2517	2517	A-2	5/8	1 3/4	18.0
8.50	8.40	2/5V850-2517	2517	E-2	0	1 3/4	13.0	3/5V850-2517	2517	A-2	5/8	1 3/4	20.0
9.00	8.90	2/5V900-2517	2517	E-2	0	1 3/4	16.0	3/5V900-2517	2517	A-2	5/8	1 3/4	20.0
9.25	9.15	2/5V925-3020	3020	E-2	0	2	17.0	3/5V925-3020	3020	A-2	0	2	21.0
9.75	9.65	2/5V975-3020	3020	E-2	0	2	19.0	3/5V975-3020	3020	A-2	0	2	24.0
10.30	10.20	2/5V1030-3020	3020	E-2	0	2	22.0	3/5V1030-3020	3020	A-2	0	2	25.0
10.90	10.80	2/5V1090-3020	3020	E-2	0	2	24.0	3/5V1090-3020	3020	A-2	0	2	27.0
11.30	11.20	2/5V1130-3020	3020	E-2	0	2	25.0	3/5V1130-3020	3020	A-2	0	2	28.0
11.80	11.70	2/5V1180-3020	3020	E-2	0	2	26.0	3/5V1180-3020	3020	A-2	0	2	29.0
12.50	12.40	2/5V1250-3020	3020	E-2	0	2	28.0	3/5V1250-3020	3020	A-2	0	2	32.0
13.20	13.10	2/5V1320-3020	3020	E-3	0	2	21.0	3/5V1320-3020	3020	A-3	0	2	34.0
14.00	13.90	2/5V1400-3020	3020	E-3	0	2	23.0	3/5V1400-3020	3020	A-3	0	2	36.0
15.00	14.90	2/5V1500-3020	3020	E-3	0	2	26.0	3/5V1500-3020	3020	A-3	0	2	36.0
16.00	15.90	2/5V1600-3020	3020	E-3	0	2	28.0	3/5V1600-3020	3020	A-3	0	2	38.0
18.70	18.60	2/5V1870-3020	3020	E-3	0	2	40.0	3/5V1870-3020	3020	A-3	0	2	52.0
21.20	21.10	2/5V2120-3535	3535	F-3	3/8	3 1/2	45.0	3/5V2120-3535	3535	E-3	0	3 1/2	60.0
23.60	23.50	2/5V2360-3535	3535	F-3	3/8	3 1/2	56.0	3/5V2360-3535	3535	E-3	0	3 1/2	68.0
28.00	27.90	2/5V2800-3535	3535	F-3	3/8	3 1/2	68.0	3/5V2800-3535	3535	E-3	0	3 1/2	83.0
31.50	31.40							3/5V3150-3535	3535	E-3	0	3 1/2	96.0
37.50	37.40							3/5V3750-4040	4040	F-3	1/2	4	124.0
50.00	49.90							3/5V5000-4040	4040	F-3	1/2	4	186.0

Note: Cast iron sheaves may not exceed 6500 FPM.
This speed **DOES NOT** specify if dynamic balancing
(2 plane) is required. Contact customer service to
verify whether dynamic balancing is required.

Cast Iron Sheaves - **Heavy Duty**
Bushed, **Four and Five Groove**
5V TB Sheaves

Order part number size
Example: 4/5V440-1610

For 5V & 5VX V-Belts.
See pages 113, 115 & 116.
Order TB bushings separately
Stock Bushings Located
on Pages 87-88.

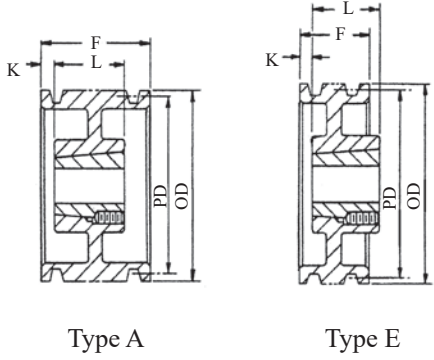
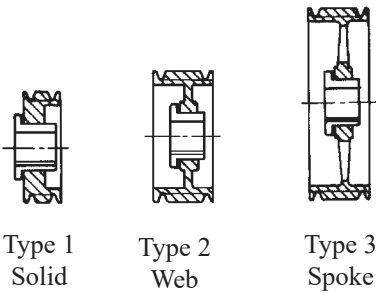
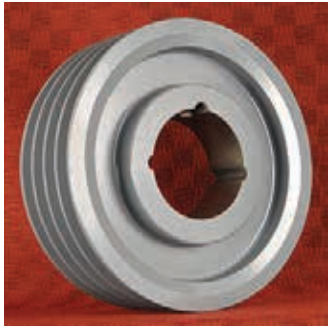

Diameters		4 Groove F = 3 1/16						5 Groove F = 3 3/4					
O.D.	P.D.	Part No.	Bush	Type	K	L	WT.	Part No.	Bush	Type	K	L	WT.
4.40	4.30	4/5V440-1610	1610	A-1	2 1/16	1	6.0						
4.65	4.55	4/5V465-1610	1610	A-1	2 1/16	1	6.0						
4.90	4.80	4/5V490-1610	1610	A-1	2 1/16	1	6.0						
5.20	5.10	4/5V520-1610	1610	A-1	1 13/16	1	7.0						
5.50	5.40	4/5V550-2517	2517	A-1	1 5/16	1 3/4	8.0						
5.90	5.80	4/5V590-2517	2517	A-1	1 5/16	1 3/4	10.0	5/5V590-2517	2517	A-1	3/4	1 3/4	11.0
6.30	6.20	4/5V630-2517	2517	A-1	1 5/16	1 3/4	11.0	5/5V630-2517	2517	A-1	3/4	1 3/4	12.0
6.70	6.60	4/5V670-2517	2517	A-1	1 5/16	1 3/4	12.0	5/5V670-2517	2517	A-1	3/4	1 3/4	13.0
7.10	7.00	4/5V710-2517	2517	A-1	1 5/16	1 3/4	15.0	5/5V710-3020	3020	A-1	1/2	2	16.0
7.50	7.40	4/5V750-2517	2517	A-1	1 5/16	1 3/4	18.0	5/5V750-3020	3020	A-1	1/2	2	19.0
8.00	7.90	4/5V800-2517	2517	A-1	1 5/16	1 3/4	21.0	5/5V800-3020	3020	A-1	1/2	2	22.0
8.50	8.40	4/5V850-2517	2517	A-1	1 5/16	1 3/4	20.0	5/5V850-3020	3020	A-1	1/2	2	26.0
9.00	8.90	4/5V900-2517	2517	A-1	1 5/16	1 3/4	22.0	5/5V900-3020	3020	A-1	1/2	2	30.0
9.25	9.15	4/5V925-3020	3020	A-2	1/2	2	27.0	5/5V925-3020	3020	A-2	1/2	2	31.0
9.75	9.65	4/5V975-3020	3020	A-2	1/2	2	31.0	5/5V975-3020	3020	A-2	1/2	2	36.0
10.30	10.20	4/5V1030-3020	3020	A-2	1/2	2	28.0	5/5V1030-3020	3020	A-2	1/2	2	33.0
10.90	10.80	4/5V1090-3020	3020	A-2	1/2	2	31.0	5/5V1090-3020	3020	A-2	1/2	2	36.0
11.30	11.20	4/5V1130-3020	3020	A-2	1/2	2	32.0	5/5V1130-3020	3020	A-2	1/2	2	38.0
11.80	11.70	4/5V1180-3020	3020	A-2	1/2	2	34.0	5/5V1180-3020	3020	A-2	1/2	2	40.0
12.50	12.40	4/5V1250-3020	3020	A-2	0	2	40.0	5/5V1250-3535	3535	A-2	0	3 1/2	54.0
13.20	13.10	4/5V1320-3020	3020	A-2	0	2	42.0	5/5V1320-3535	3535	A-2	0	3 1/2	57.0
14.00	13.90	4/5V1400-3535	3535	A-3	0	3 1/2	48.0	5/5V1400-3535	3535	A-2	0	3 1/2	57.0
15.00	14.90	4/5V1500-3535	3535	A-3	0	3 1/2	52.0	5/5V1500-3535	3535	A-3	0	3 1/2	65.0
16.00	15.90	4/5V1600-3535	3535	A-3	0	3 1/2	53.0	5/5V1600-3535	3535	A-3	0	3 1/2	70.0
18.70	18.60	4/5V1870-3535	3535	A-3	0	3 1/2	63.0	5/5V1870-3535	3535	A-3	0	3 1/2	84.0
21.20	21.10	4/5V2120-3535	3535	A-3	0	3 1/2	70.0	5/5V2120-4040	4040	E-3	0	4	81.0
23.60	23.50	4/5V2360-3535	3535	A-3	0	3 1/2	79.0	5/5V2360-4040	4040	E-3	0	4	92.0
28.00	27.90	4/5V2800-3535	3535	A-3	0	3 1/2	98.0	5/5V2800-4040	4040	E-3	0	4	115.0
31.50	31.40	4/5V3150-3535	3535	A-3	0	3 1/2	114.0	5/5V3150-4040	4040	E-3	0	4	115.0
37.50	37.40	4/5V3750-4040	4040	A-3	0	4	148.0	5/5V3750-4040	4040	E-3	0	4	190.0
50.00	49.90	4/5V5000-4040	4040	A-3	0	4	243.0	5/5V5000-4545	4545	E-3	0	4 1/2	280.0

Note: Cast iron sheaves may not exceed 6500 FPM.
This speed **DOES NOT** specify if dynamic balancing
(2 plane) is required. Contact customer service to
verify whether dynamic balancing is required.

TB Bushing Sheaves

Cast Iron Sheaves - **Heavy Duty**

Bushed, **Six Groove**

5V TB Sheaves

Order part number size

Example: 6/5V590-2517

For **5V & 5VX V-Belts**.

See pages 113, 115 & 116.

Order TB bushings separately

Stock Bushings Located

on Pages 87-88.

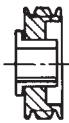

Type 1
Solid



Type 2
Web



Type 3
Spoke

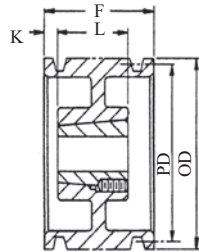

Type A

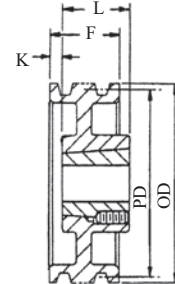

Type E

Diameters		6 Groove F = 4 7/16					
O.D.	P.D.	Part No.	Bush	Type	K	L	WT.
5.90	5.80	6/5V590-2517	2517	A-1	1	1 3/4	13.0
6.30	6.20	6/5V630-2517	2517	A-1	1	1 3/4	13.0
6.70	6.60	6/5V670-2517	2517	A-1	1	1 3/4	15.0
7.10	7.00	6/5V710-3020	3020	A-1	3/4	2	18.0
7.50	7.40	6/5V750-3020	3020	A-1	3/4	2	21.0
8.00	7.90	6/5V800-3020	3020	A-1	3/4	2	24.0
8.50	8.40	6/5V850-3020	3020	A-1	3/4	2	28.0
9.00	8.90	6/5V900-3020	3020	A-1	3/4	2	32.0
9.25	9.15	6/5V925-3535	3535	A-1	0	3 1/2	41.0
9.75	9.65	6/5V975-3535	3535	A-1	0	3 1/2	48.0
10.30	10.20	6/5V1030-3535	3535	A-1	0	3 1/2	56.0
10.90	10.80	6/5V1090-3535	3535	A-1	0	3 1/2	65.0
11.30	11.20	6/5V1130-3535	3535	A-1	0	3 1/2	53.0
11.80	11.70	6/5V1180-3535	3535	A-2	0	3 1/2	59.0
12.50	12.40	6/5V1250-3535	3535	A-2	0	3 1/2	59.0
13.20	13.10	6/5V1320-3535	3535	A-2	0	3 1/2	67.0
14.00	13.90	6/5V1400-3535	3535	A-3	0	3 1/2	67.0
15.00	14.90	6/5V1500-4040	4040	A-3	0	4	82.0
16.00	15.90	6/5V1600-4040	4040	A-3	0	4	84.0
18.70	18.60	6/5V1870-4040	4040	A-3	0	4	97.0
21.20	21.10	6/5V2120-4040	4040	A-3	0	4	91.0
23.60	23.50	6/5V2360-4040	4040	A-3	0	4	124.0
28.00	27.90	6/5V2800-4040	4040	A-3	0	4	149.0
31.50	31.40	6/5V3150-4040	4040	A-3	0	4	171.0
37.50	37.40	6/5V3750-4545	4545	E-3	0	4 1/2	214.0
50.00	49.90	6/5V5000-4545	4545	E-3	0	4 1/2	336.0

Note: Cast iron sheaves may not exceed 6500 FPM.
This speed **DOES NOT** specify if dynamic balancing
(2 plane) is required. Contact customer service to
verify whether dynamic balancing is required.